

CTT

Car Turn Table

PROFESSIONAL PARKING SOLUTION PROVIDER!



WE PLAN , DESIGN, AND INSTALL...

Introduction

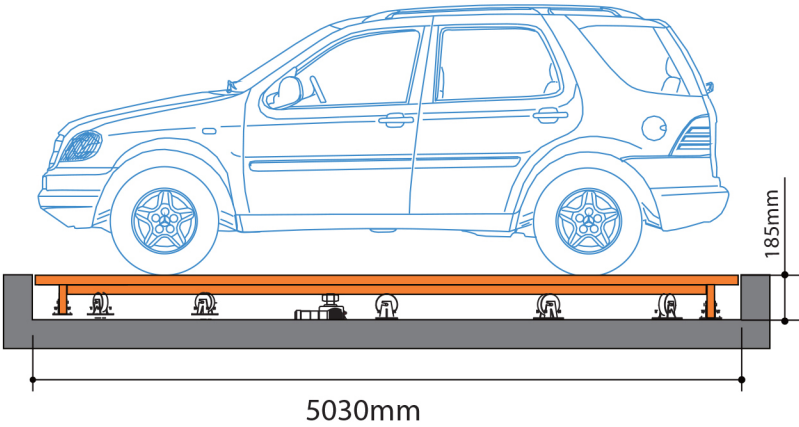

Car Turn Table is an affordable driveway solution, which can be installed quickly and efficiently to solve steep driveway issues and small access locations, or for car exhibition to create a dynamic environment to help draw attention to your automotive display. Together with Car stacking solutions, it can be installed where residence have multiple cars and insufficient garage spaces.

Our Car Turn Table adds significant value to your property and provide a safe solution to residences located on busy roads. Different surface finishes are available for your different requirement. Our turntables can be totally customized on diameter, capacity, and coverage of platform to meet individual building requirements.

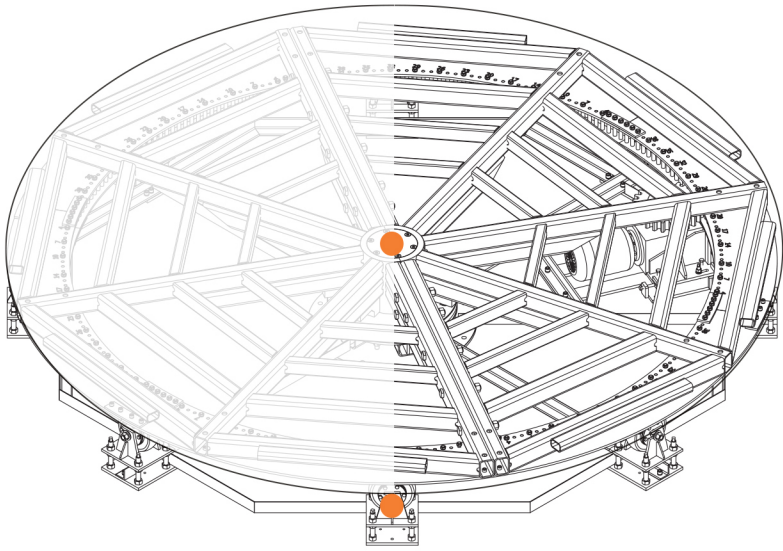

General Parts

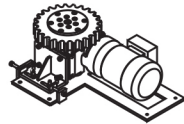
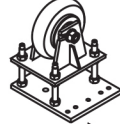

- Center Bearing 
- Motor 
- Supporting Wheel 
- Structure 

Why Use Ateco Car Turntable?



1. Quality Assurance by manufacturer : we adopt laser cutting technology and precision manufacturing techniques, allowing us to deliver the smoothest and quietest turntables.

2. Thinner design:

Our new design makes machine thickness only 185mm

3. Quiet operation:

Thanks to updated design, there is no noise during operation

4. Advanced drive system:

A circle of Pin-Gear mechanism is driven by motor to turn platform smoothly and exactly.

5. Professional package:

Most of parts are package in a wooden box, which is easy for loading and unloading.

6. High customization:

Different diameter, capacity and coverage of platform could be customized according to clients' requests.

Easy maintenance:

A key component to Ateco Turntable success has been the robust and reliable designs that incorporate easily accessed and changed out components. Quality Parts from reputable suppliers available worldwide are used in our turntables to ensure any issues can be quickly rectified.

Specification

Model	CTT
Drive mode	Electric motor
Diameter	1.2-35m *can be customized according to customers' requirements
Loading capacity	1-20ton *can be customized according to customers' requirements
Motor power	0.75kw *can be customized according to customers' requirements
Voltage	380v, 50hz, 3P *can be customized according to customers' requirements
Turning speed	0.2-2rpm
Turning angle	360 any direction
Min. height	185mm
Finishing	Powder coating
Coverage of platform	Diamond plate / Aluminium alloy plate
Operation	Button/ remote control/PLC * can be customized according to customers' requirements

Drawing

CTT

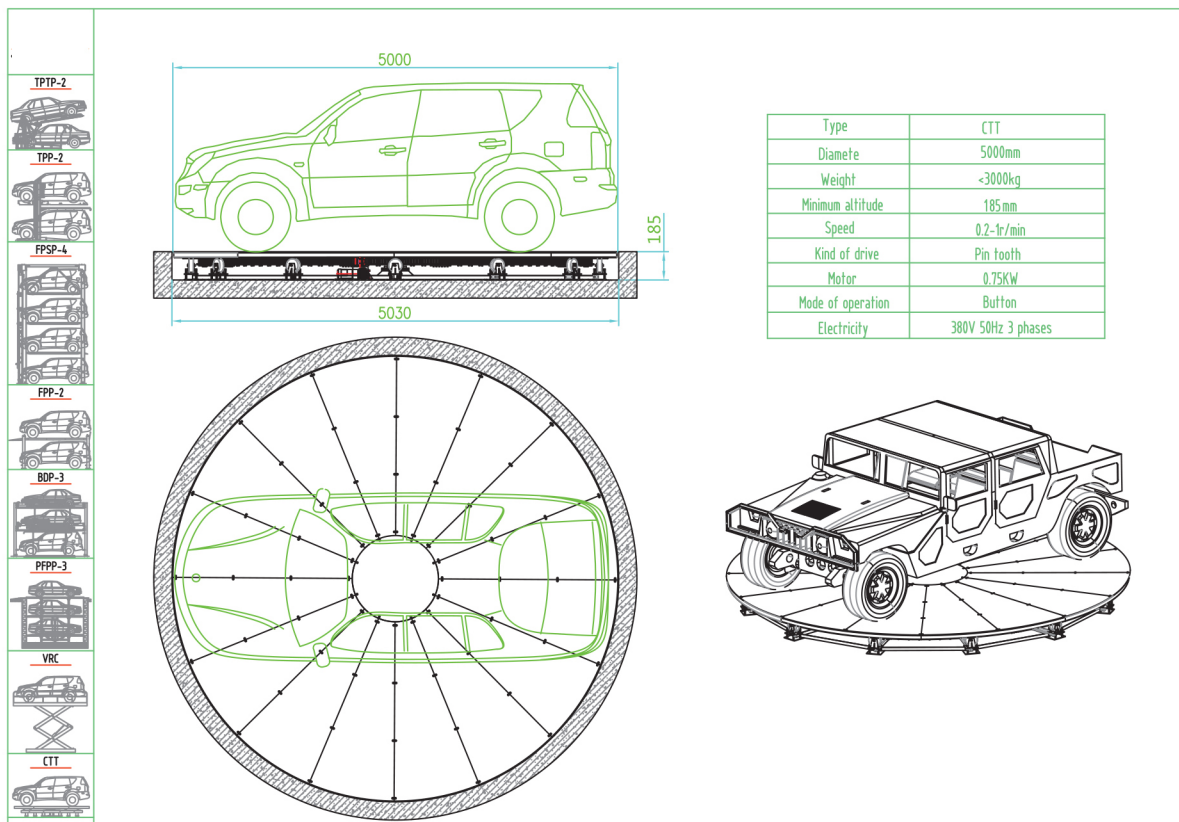



- A vehicle drives onto the tray
- turn power on, and press the motor button to start
- Remote control is optional.

Package and container by manufacturer



Most of parts are packed into a wooden box, which is easy for shipment.

Wiring diagram

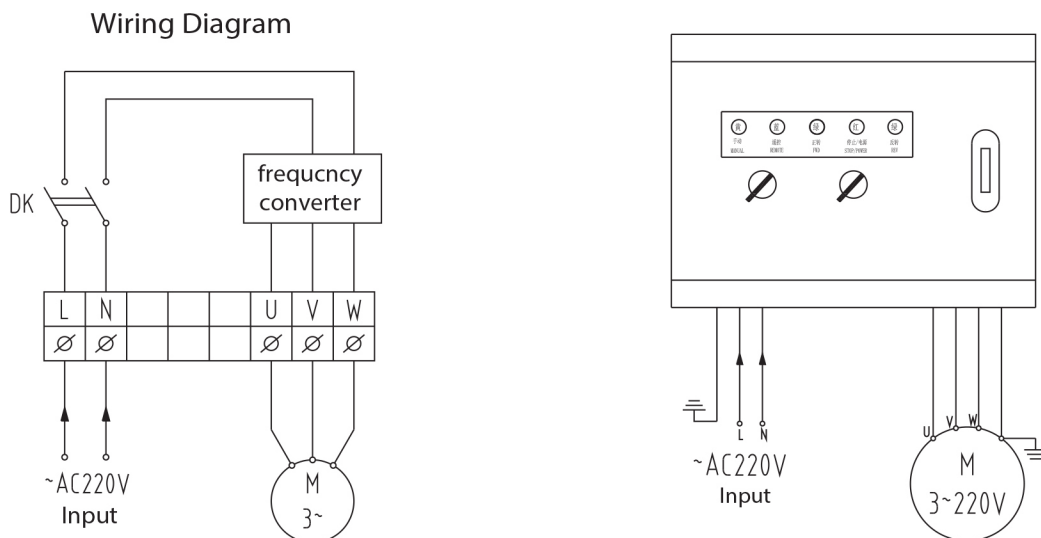

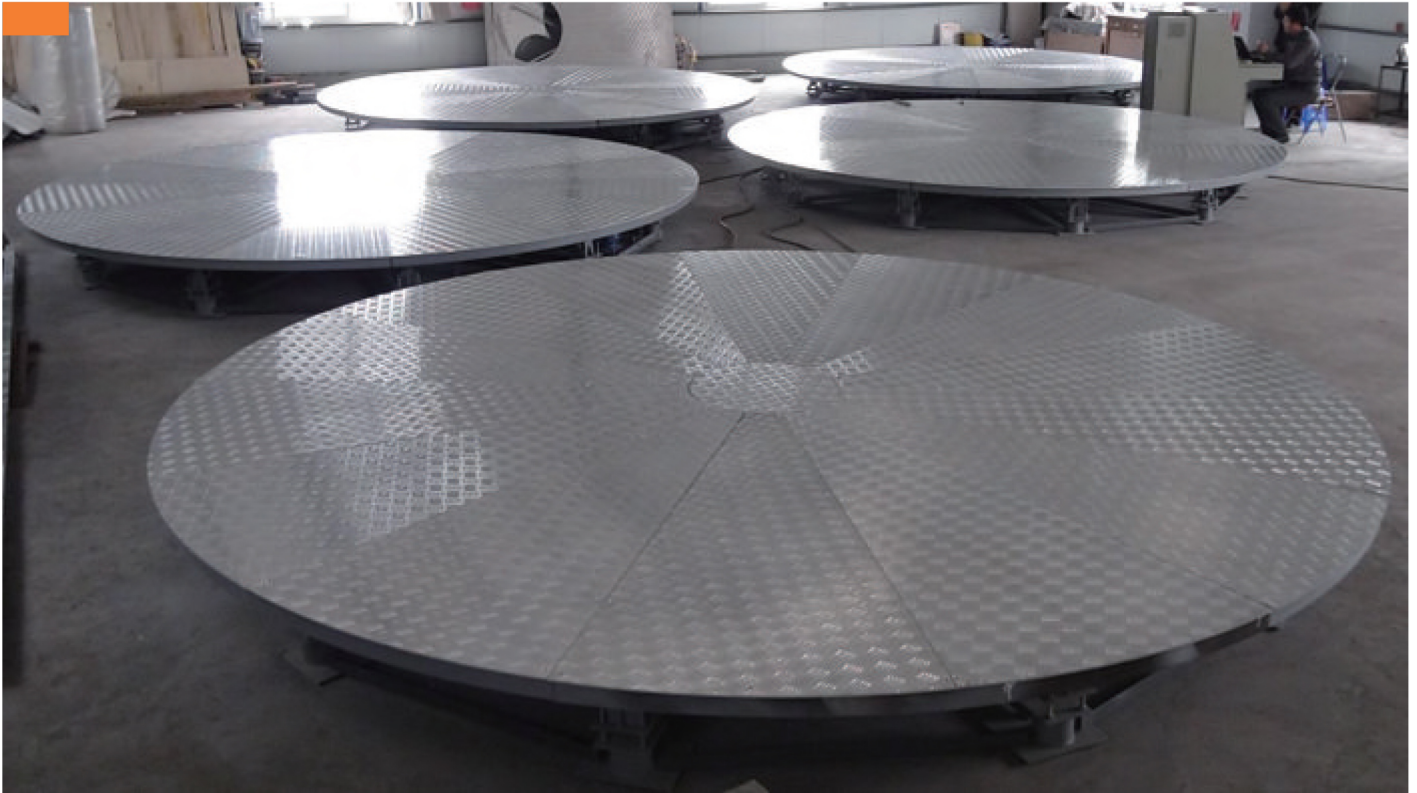



ATECO CORPORATION

اتيكو كورپوريشن



Address of Offices:

- 20 Samir Abdelrauf, extention Makram Ebid St., Nasr City, Cairo, Egypt.
- Financial Center (140), Zone 1. Banking Road, From 90th Street. First floor. Red-Con Building, New Cairo - Cairo Governorate 11835, Egypt.

Tel No.:+202 2677 5416

:+202 2677 5125

Mobile: +201022000282

Website: www.ateco.co

Email: info@ateco.co

Facebook: fb.me/ateco.parking